

Ornithopter

© Jens-Helge Dahmen

Date: 09/2007

Paper size: 35x35 cm

- 1 Colored side up. Fold and unfold in half in both directions.

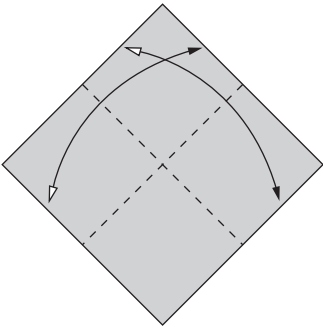

- 2 Divide the paper in fourth in both directions.

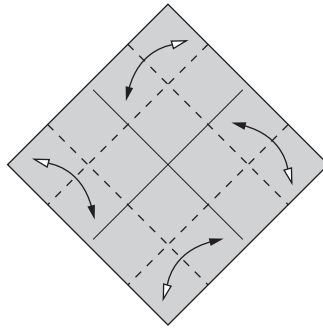

- 3 Fold a preliminary base with all corners.

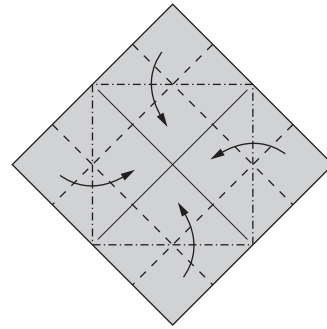

- 4 Fold and unfold both diagonals.

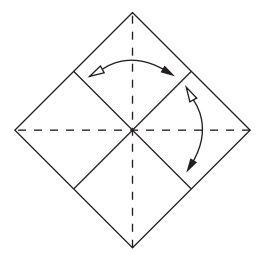

- 5 Four petal folds.

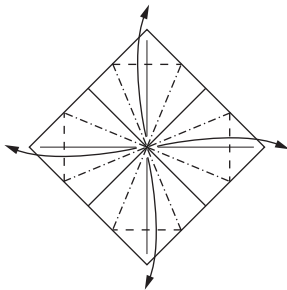

- 6 Valley fold four creases.

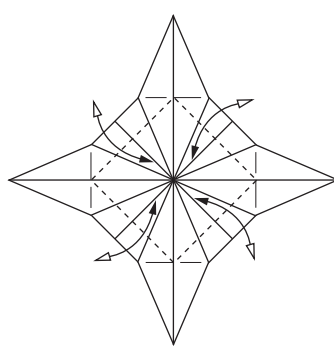

- 7 Mountain fold four creases.

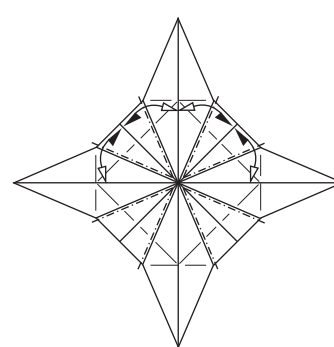

- 8 Valley fold eight creases.

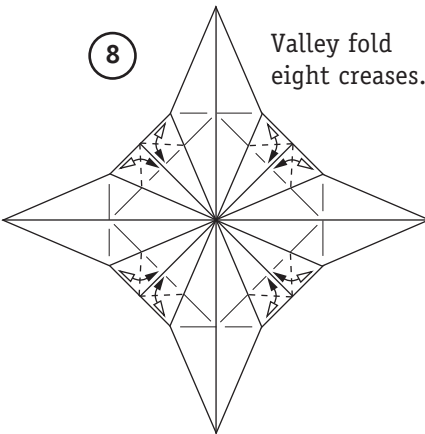

- 9 Fold the four tips to the center.

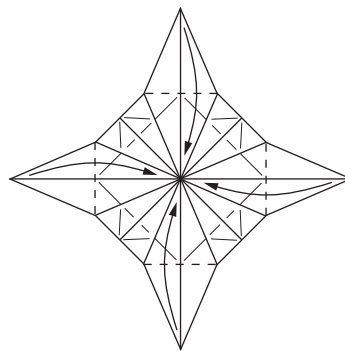

- 10 Open sink the four corners.

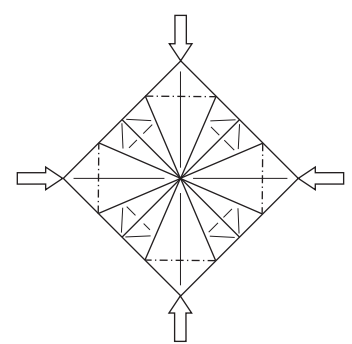

- 11 Fold the four tips outward.

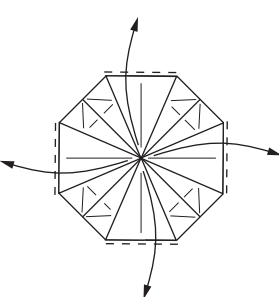

- 12 Color change with the four tips.

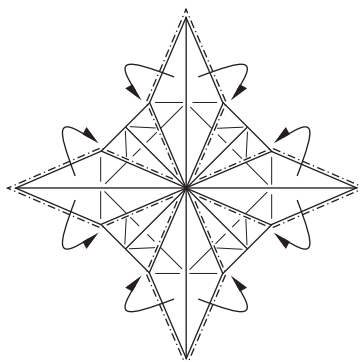

- 13 Preliminary base.

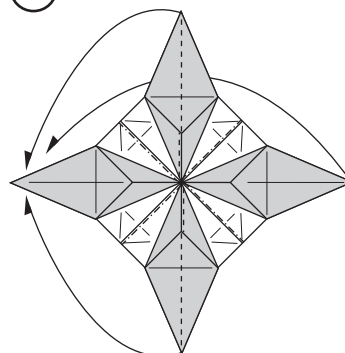

14 Four inside reverse folds.

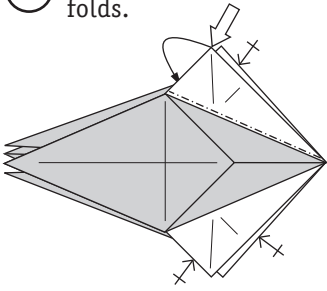

15 Fold the four left tips to the right.

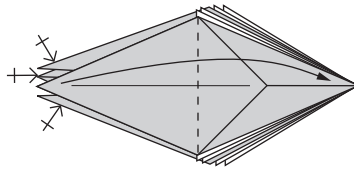

16 Fold one flap upward.

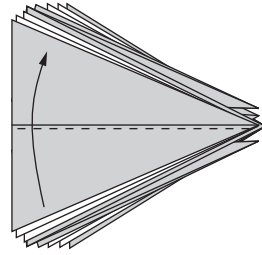

17 Took the upper two colored flaps (A, B) and unfold in swiveling to the right. The two white flaps C and D shall be unfolded. See next step.

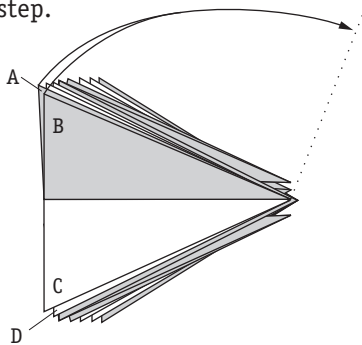

18 Like this.

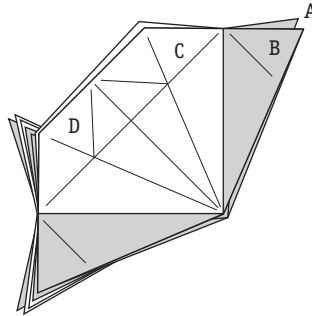

19 Lift the first layer a little and...

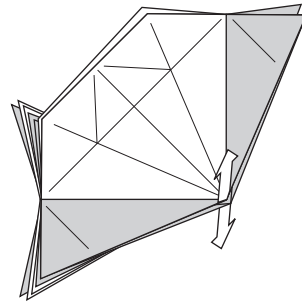

20 ... rearrange the creases as shown. Collapse the model in pleating a sting with the first layer. The corner A will be the tip of the sting.

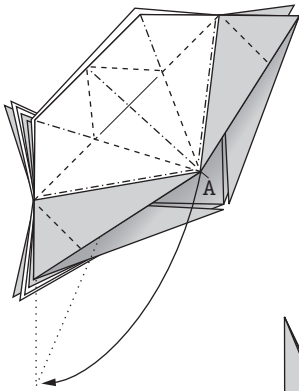

21 Fold one flap down.

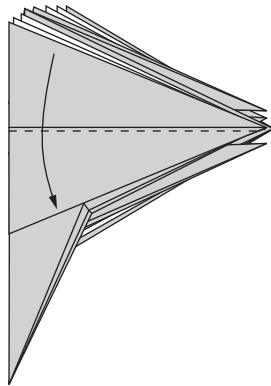

22 Repeat the steps 18-20 on the upper flaps A-D.

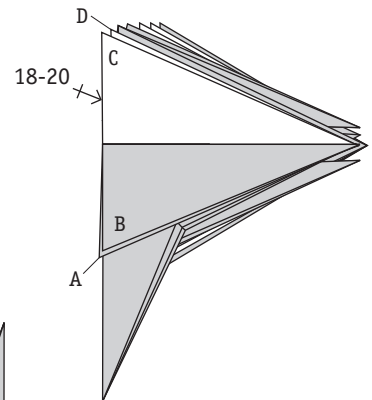

23 Turn over.

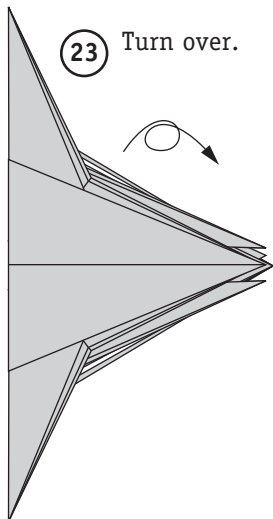

24

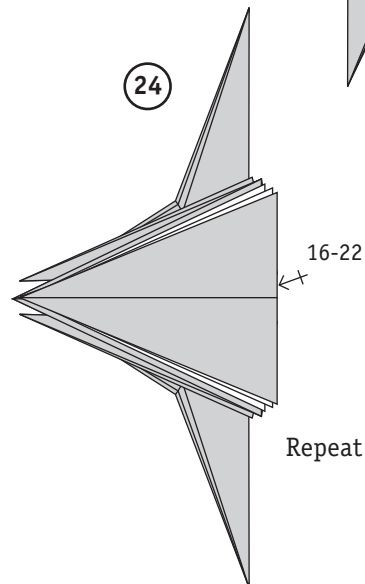

Repeat the steps 16-22.

25

Fold the left upper flap to the right.

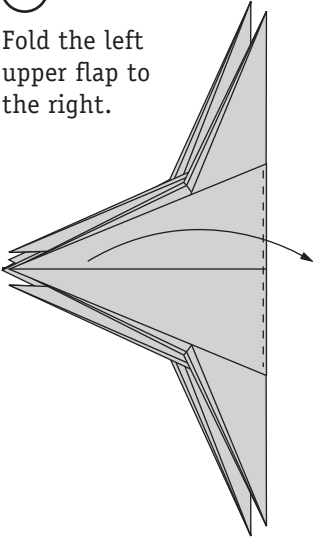

26

Pull out the hidden layers on the right flap. The model don't lie flat.

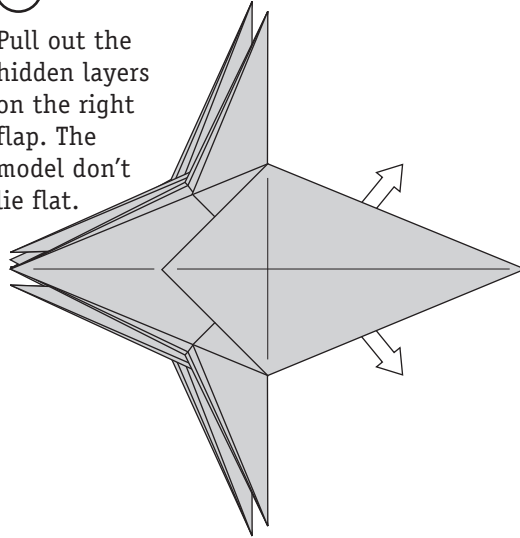

27

Stretch the right flap to the right to get more opened. The model don't lie flat.

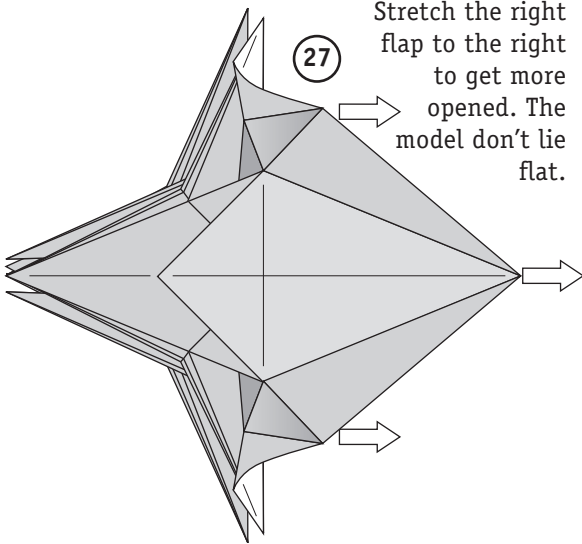

28

Press out the valley fold A and B. The marked hidden valley folds invert to mounain folds. The model don't lie flat.

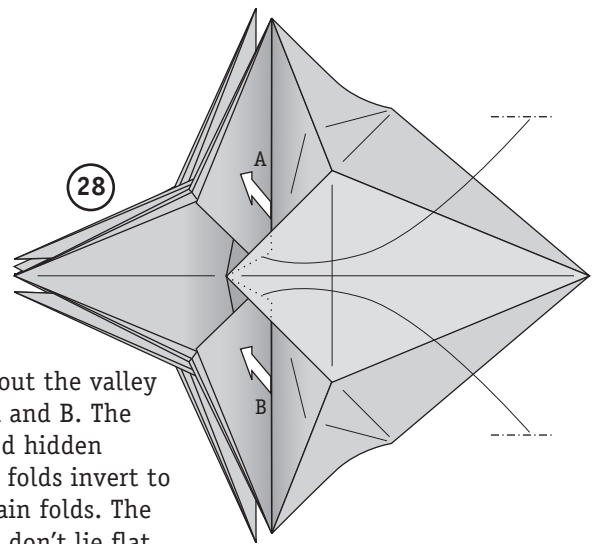

29

Precrease two mountain folds on the upper layer only. Note the red reference points and the right angle.

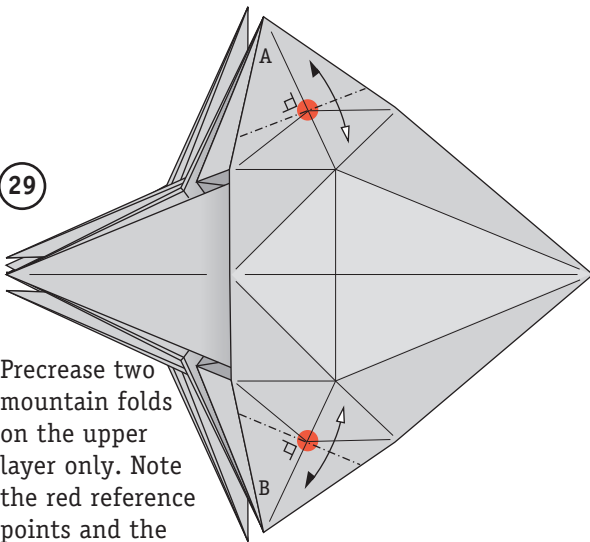

30

Precrease two valley folds on the upper layer only. Note the red reference points and the right angle. Each of both valley folds is straitaway over all section of the upper flap!

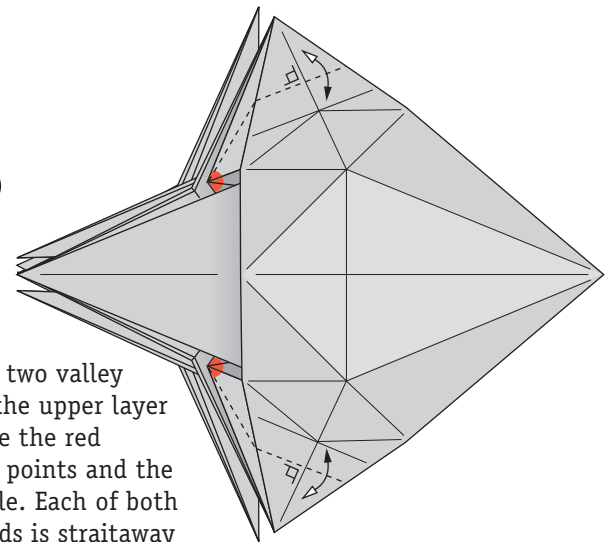

31

Collapse the upper layer as shown in using the creases from

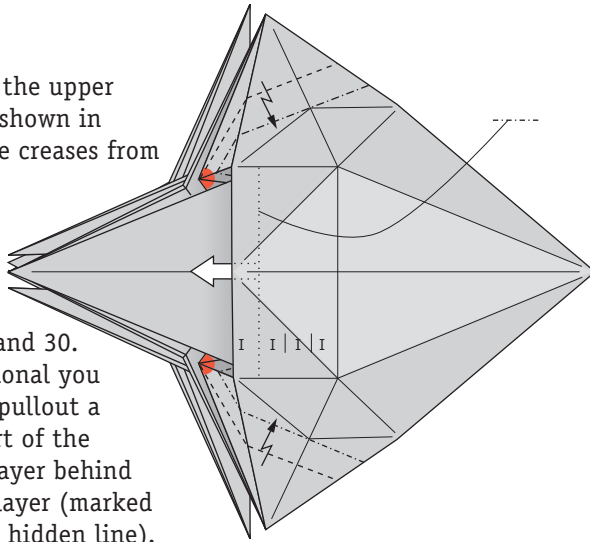

step 29 and 30. In addition you need to pullout a little part of the hidden layer behind the top layer (marked with the hidden line).

32

Turn over.

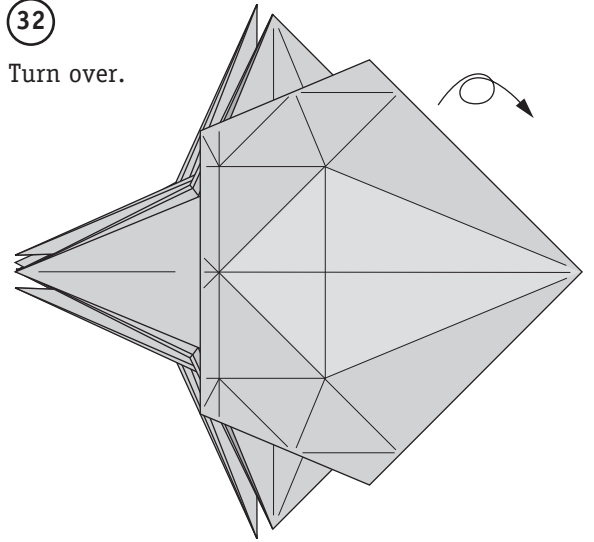

33

Fold one sting upward together with all related flaps.

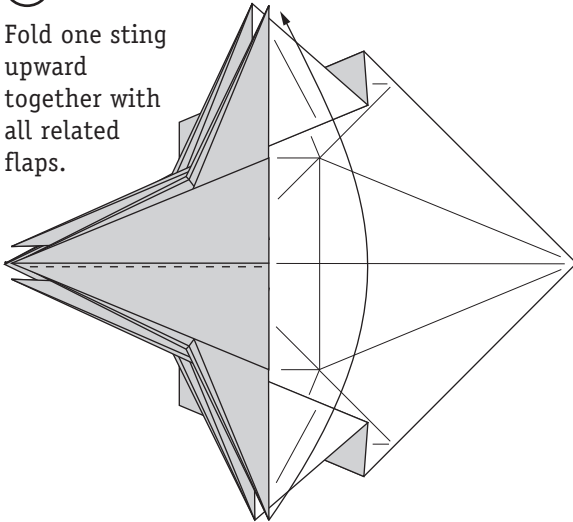

34

Fold the upper left flap to the right.

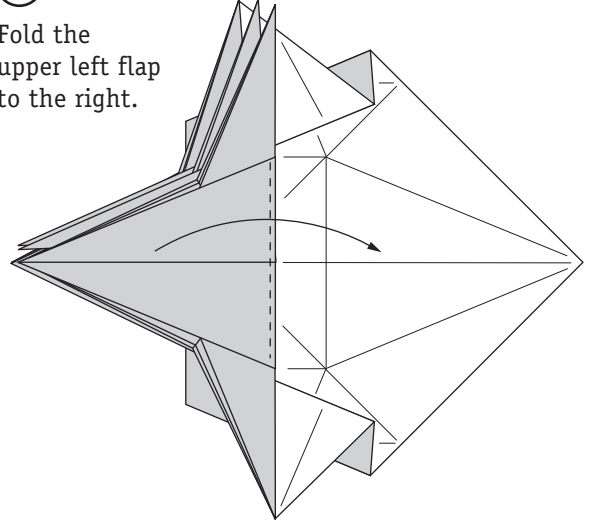

35

Color changing on the right upper flap:

Bring the hidden layer in front. See next step.

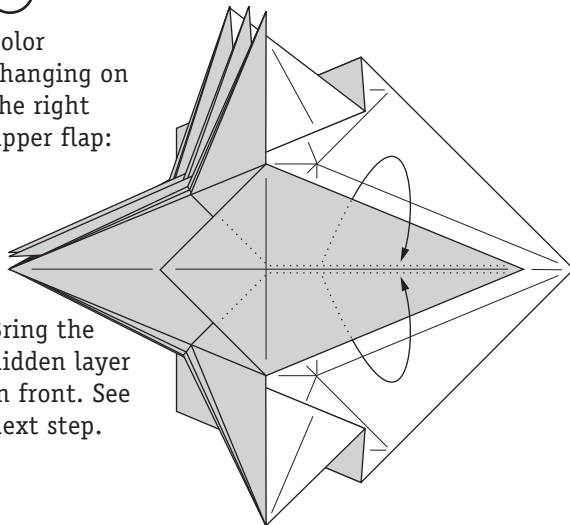

36

Inside reverse fold.

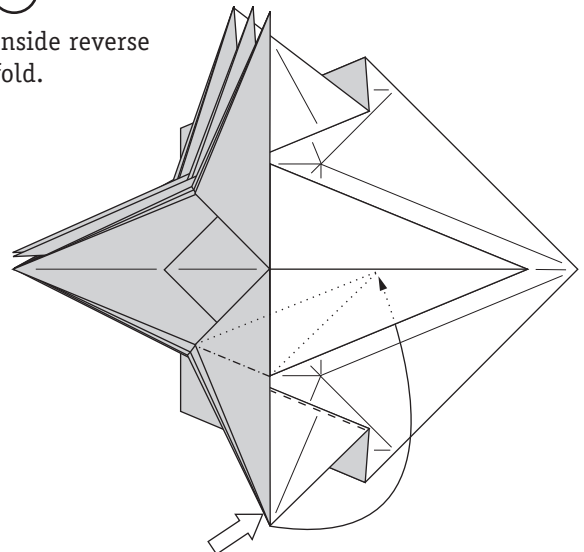

37

Fold the upper sting down.

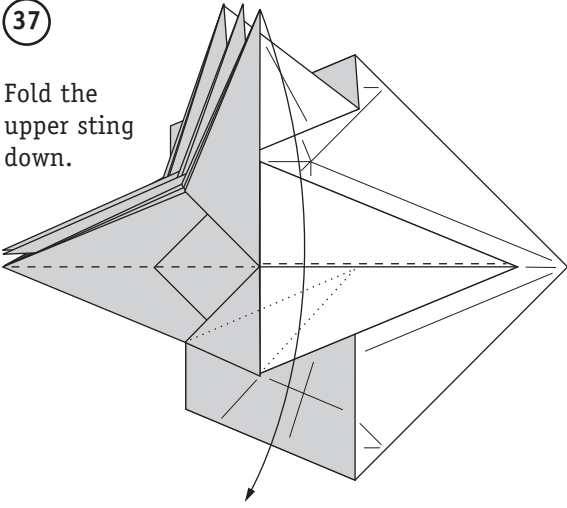

38

Repeat the steps 33-37 on the other side.

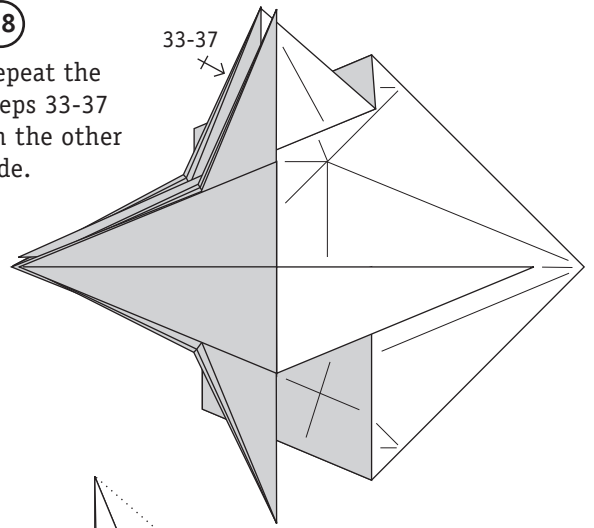

39

Pleat the wings: Two inside reverse folds.

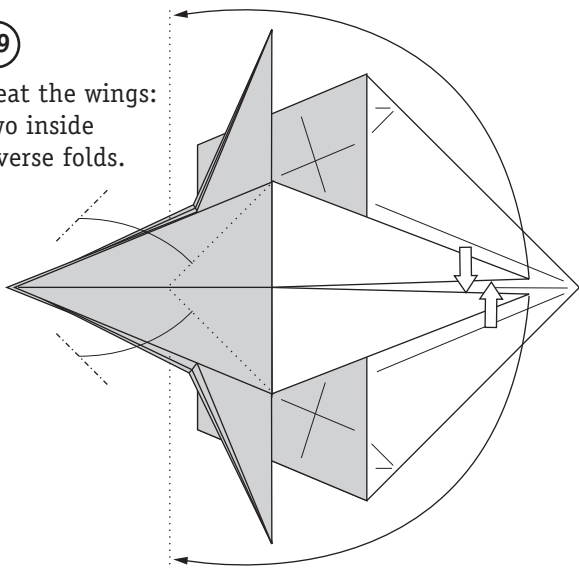

40

Swivel fold the upper layer on both wings.

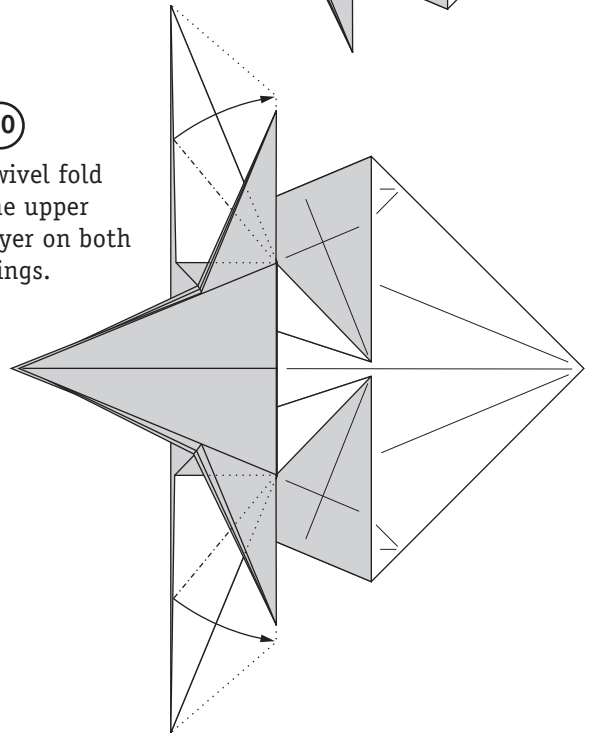

41

Pleat the tail: Two inside reverse folds on the right lower flap.

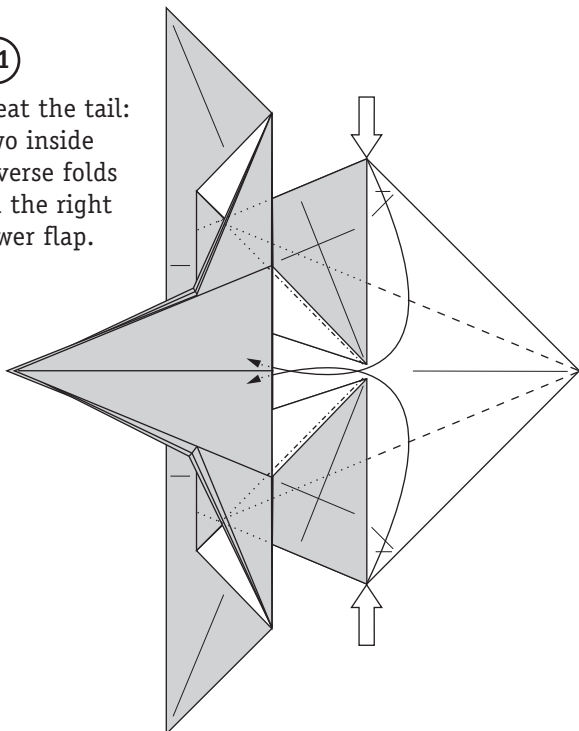

42

Turn over.

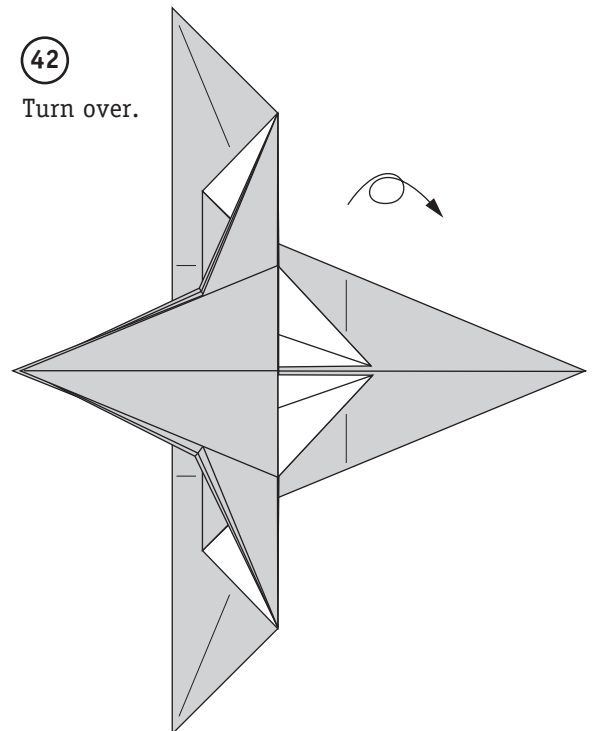

43

Swivel fold
the upper
layer on both
wings.

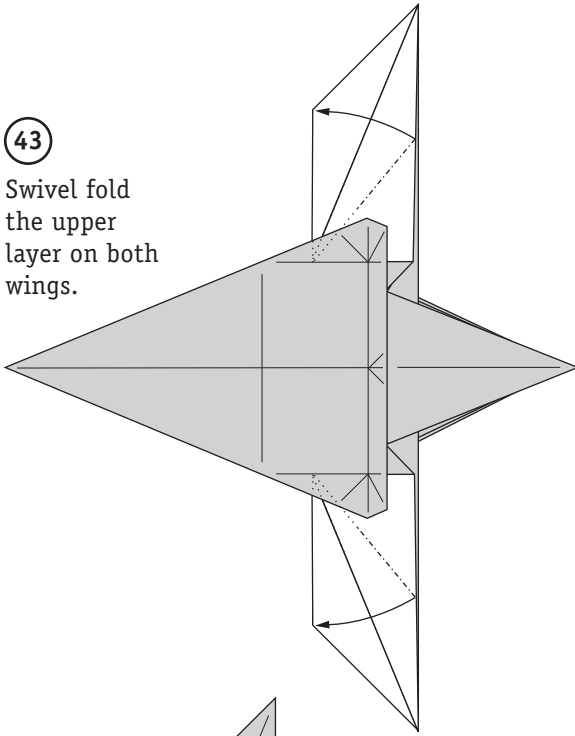

44

Fold to the
center line
two times.

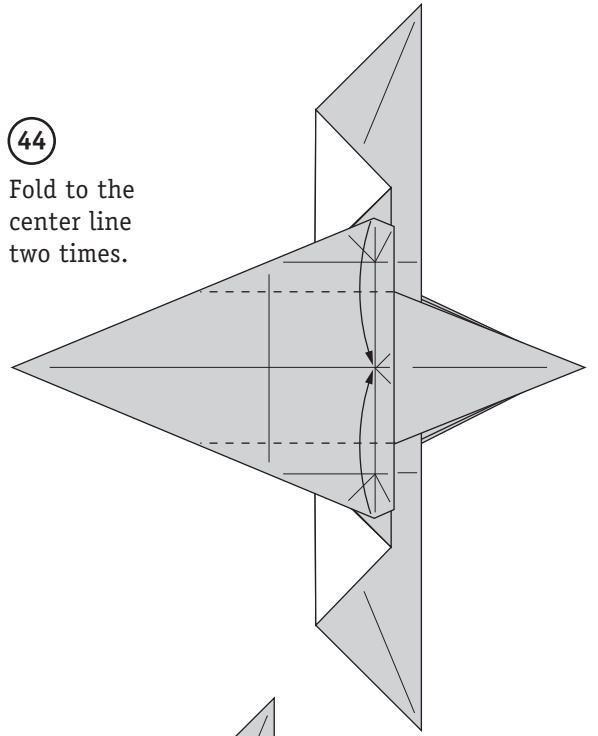

45

Reducing the
tail with two
valley folds.

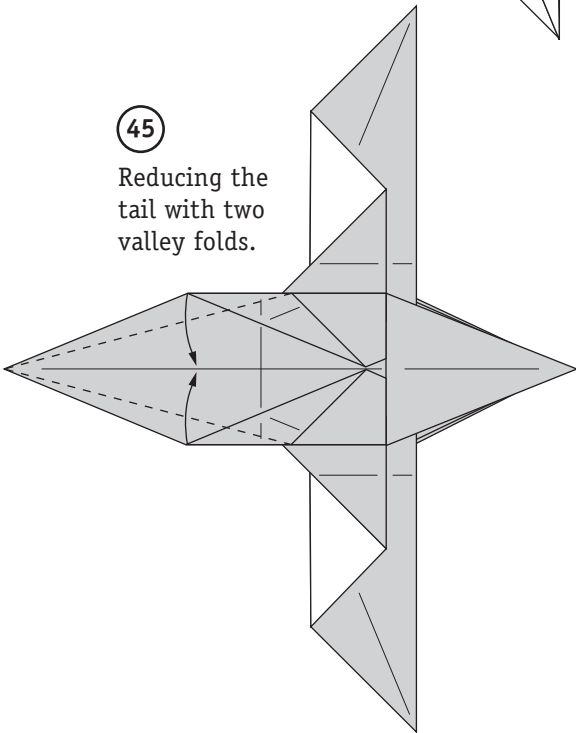

46

Swivel fold on
the upper
layer on both
sides.

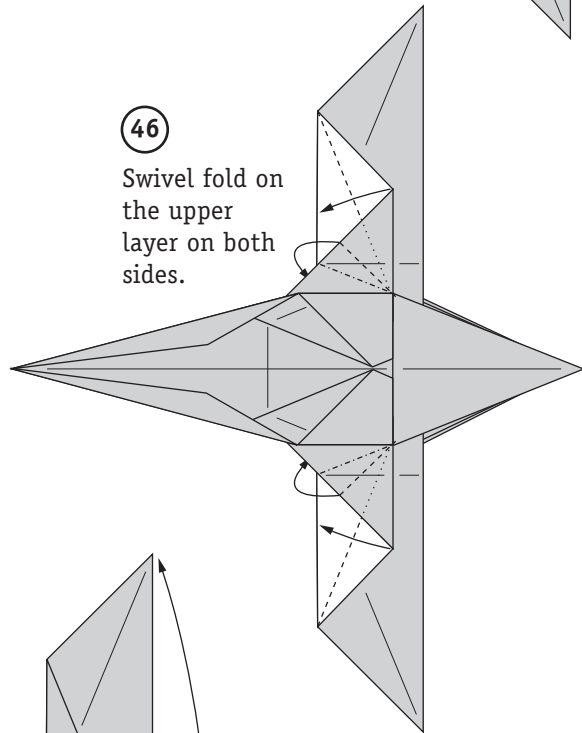

47

Fold the
model in half.

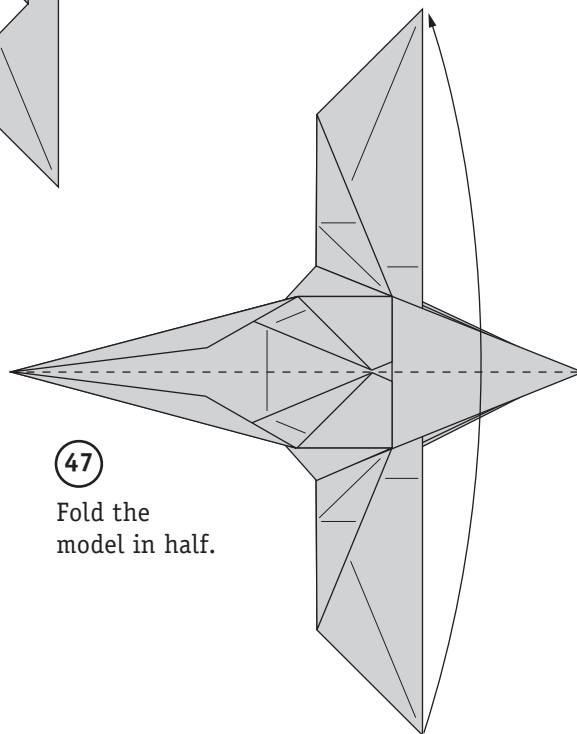

48

Fold the upper Sting down and swivel fold the interconnected layer between sting and wing. Repeat behind.

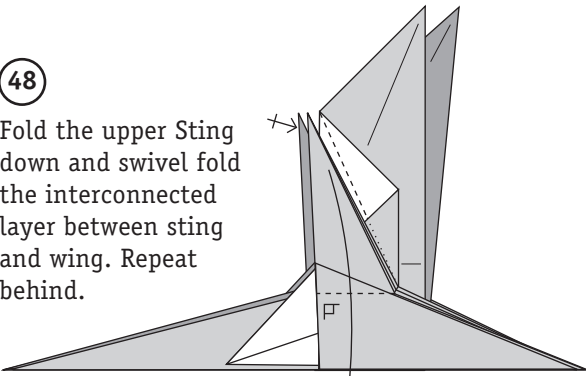

49

Fold the sting back. Repeat behind.

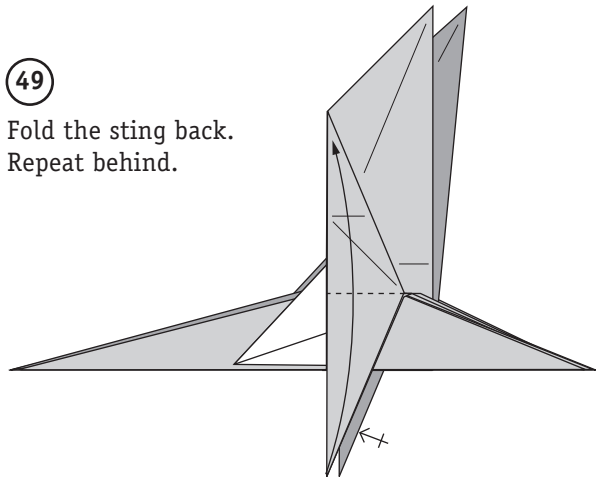

50

Rabbit ear on the upper short flap. Repeat behind.

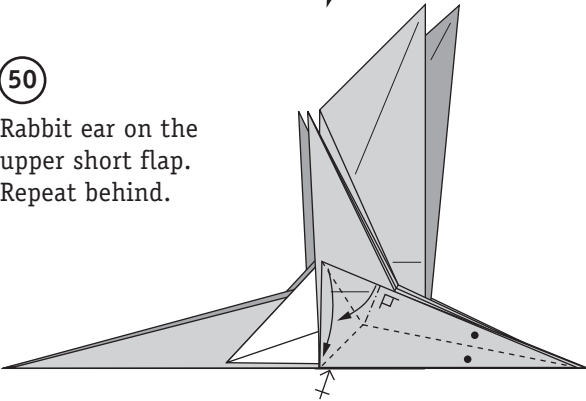

51

Rabbit ear on the upper layer of the sting while folding the sting down. Repeat behind.

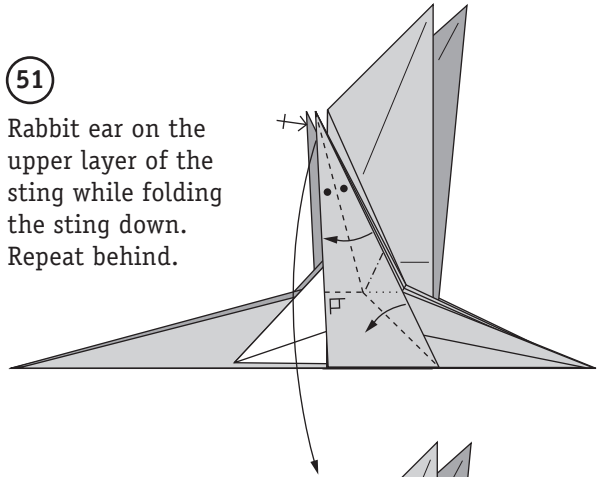

52

Fold the hind legs: Outside reverse fold. Repeat behind.

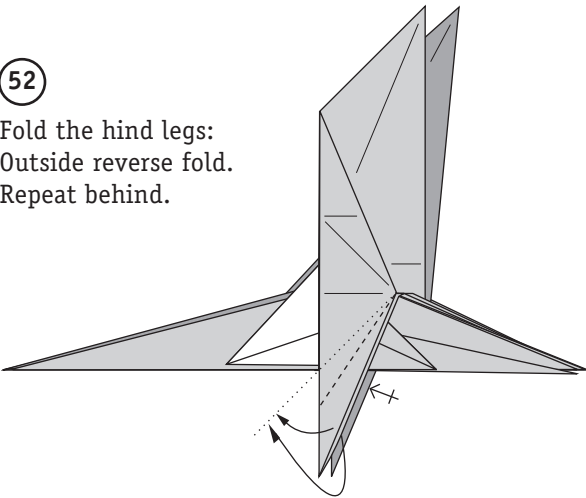

53

Fold down the wings.

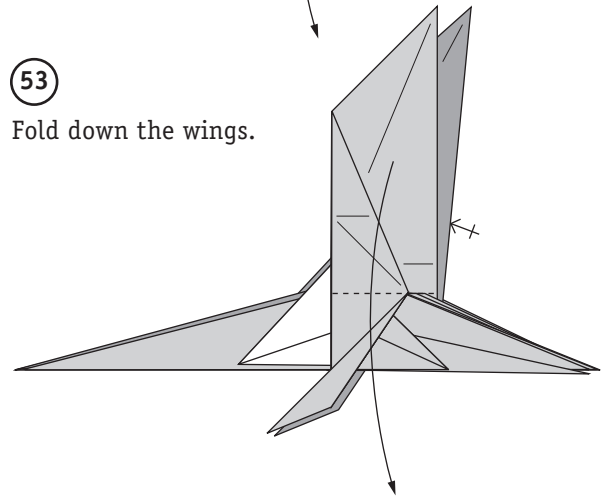

54

Inside reverse fold. Repeat behind.

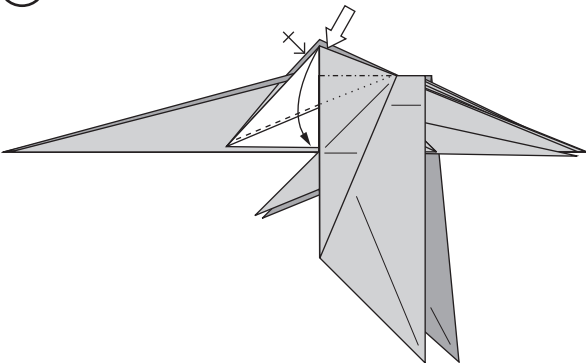

55

Inside reverse fold the tail.

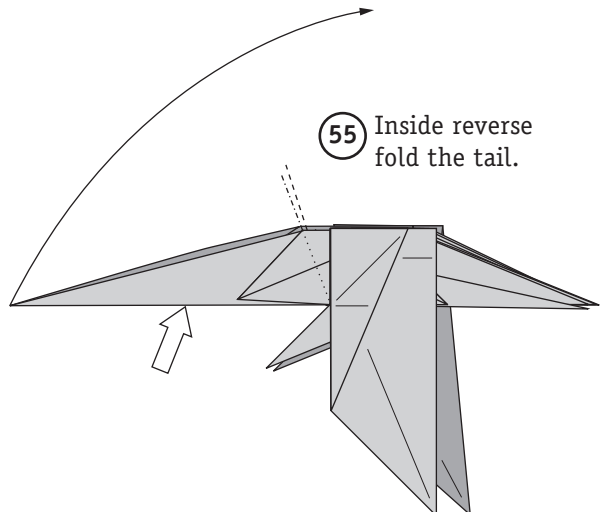

56 Inside reverse fold the tail.

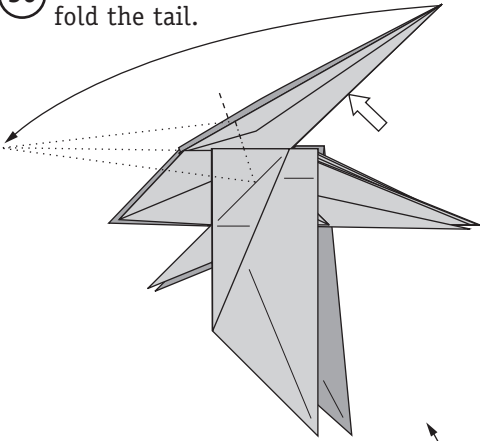

57 Lean the tail with a mountain fold on both sides.

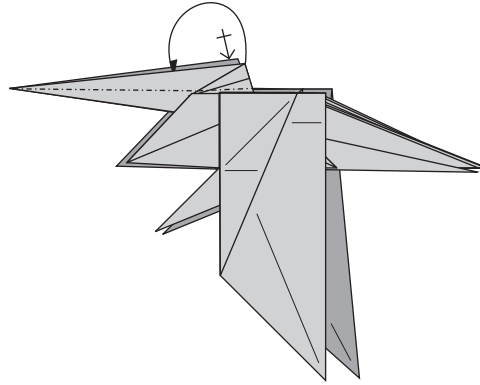

58 Fold the wings upward.

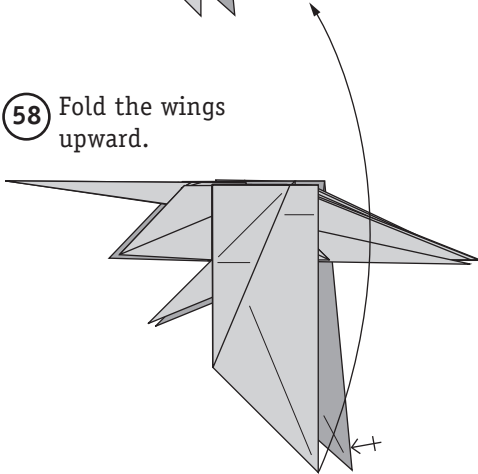

59 Two little mountain folds (no reference points) on the backside. Fold both hint legs upward. Valley fold the right central tip.

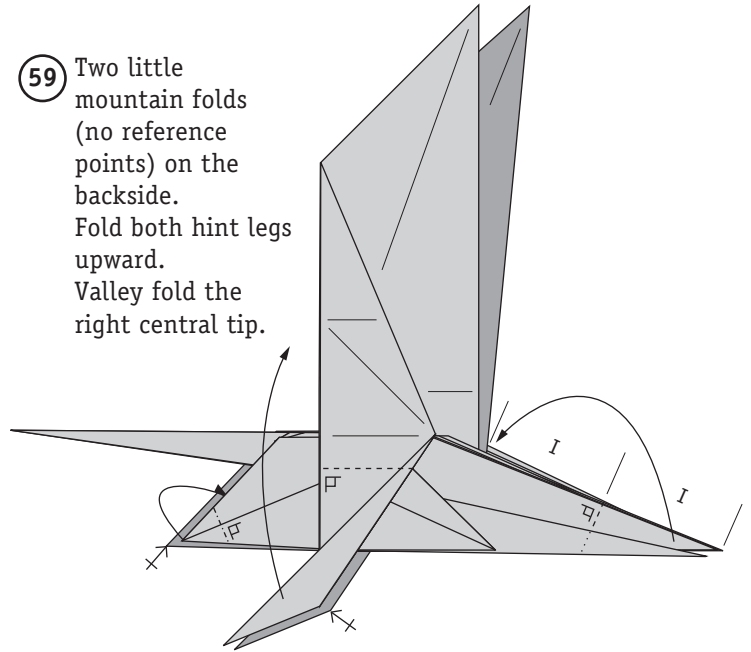

60 1: Outward reverse fold the right sting: front leg. 2: Than unfold the central tip.

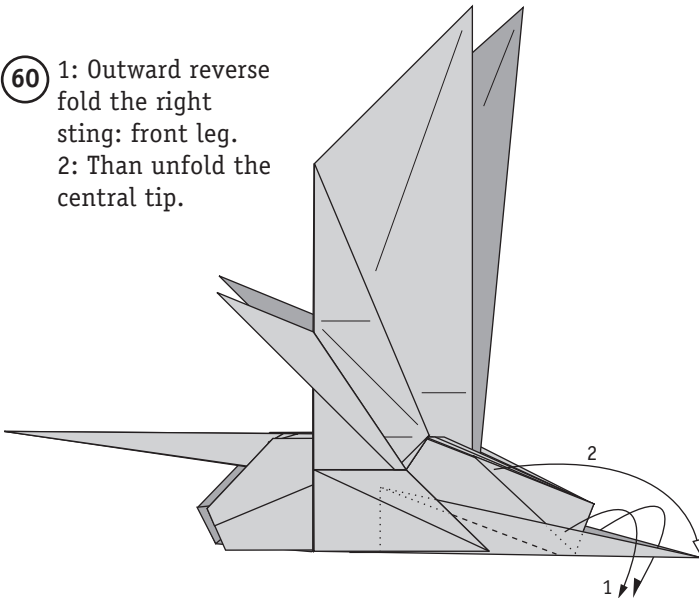

61 Squash fold the central tip on the right: cockpit. 3-dimensional rabbit ear on the short flap in the middle of the body: cannonry. Repeat behind.

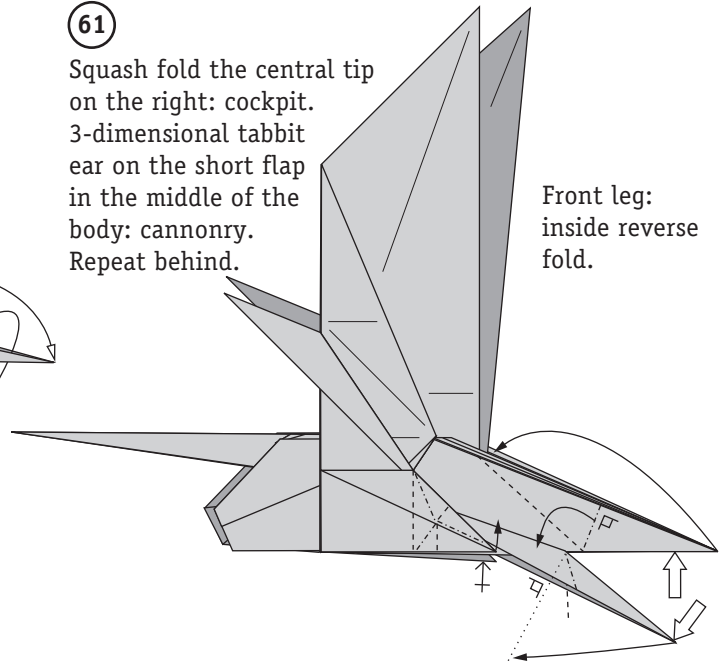

Front leg:
inside reverse
fold.

62

Backside: curve two turbojet engines 3-dimensional alike rabbit ears. Hint legs: fold down 3-dimensional with pleating a shoulder. Front leg: inside reverse fold. Cockpit: bring it in front.

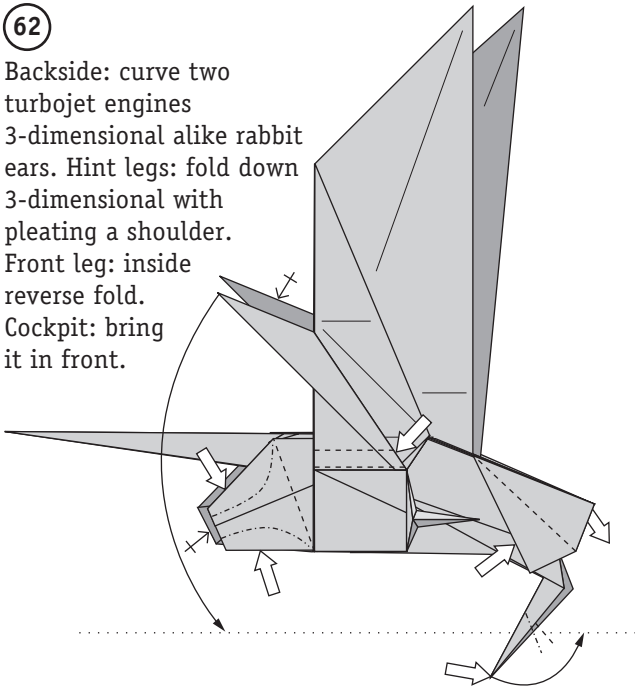

63

Fold the wings horizontally. Front leg: inside reverse fold.

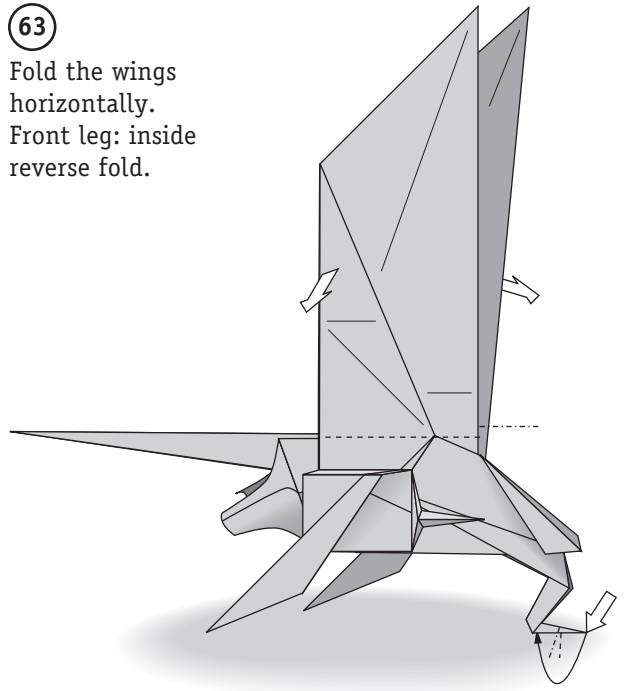

64

Finished Ornithopter with low speed wing position.

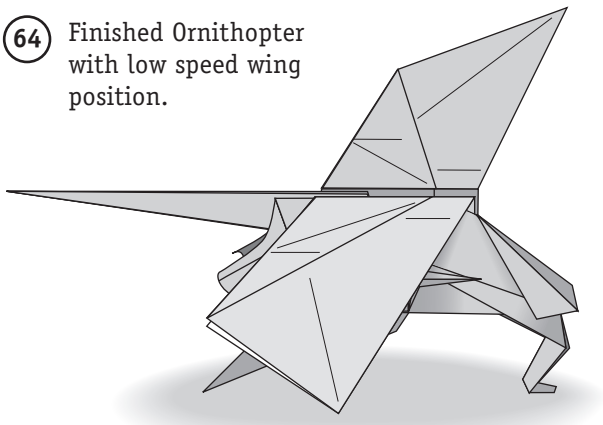

Fold a resting wing position: two valley folds.

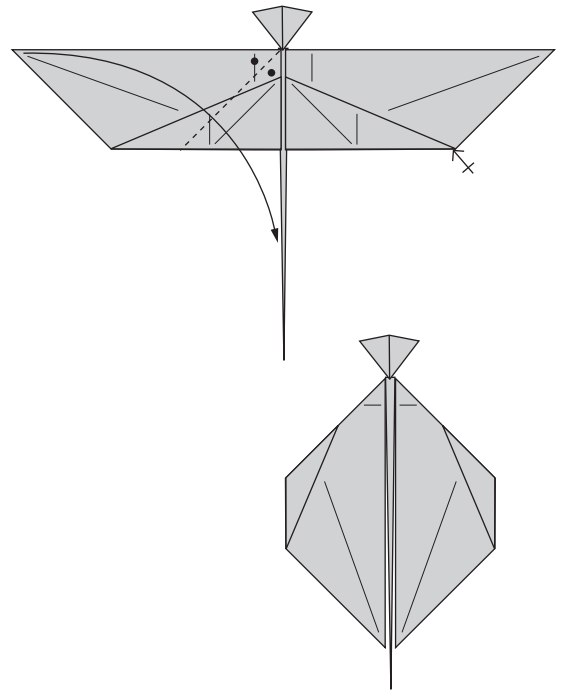

Fold a high speed wing position: two crimp-folds.

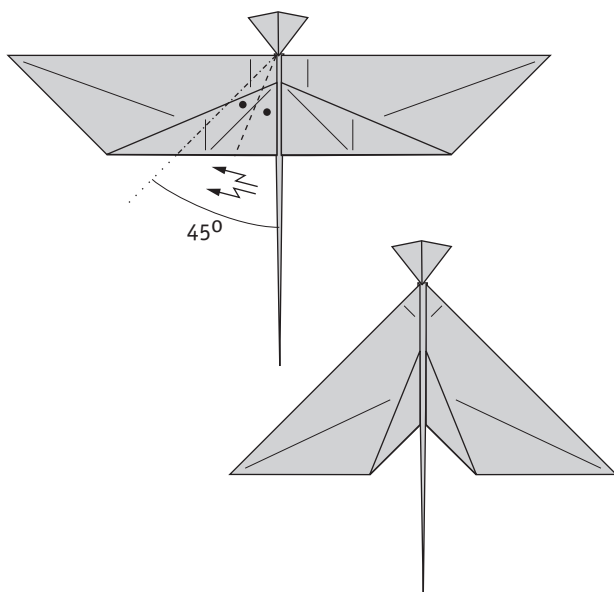

Fold two additional turbojet engines.

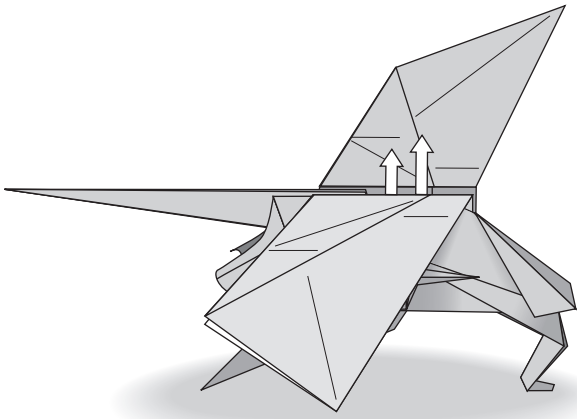

II Two pleat folds.

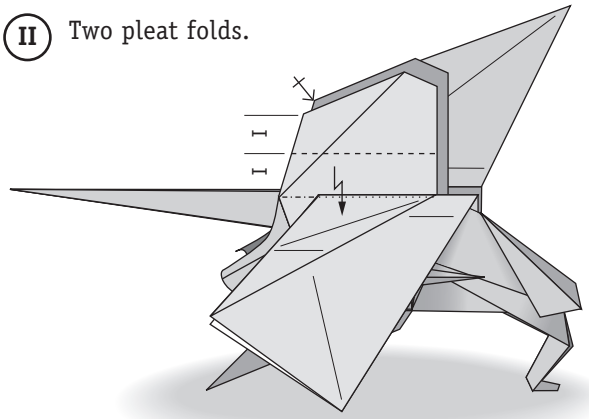

III Curve two cylinders.

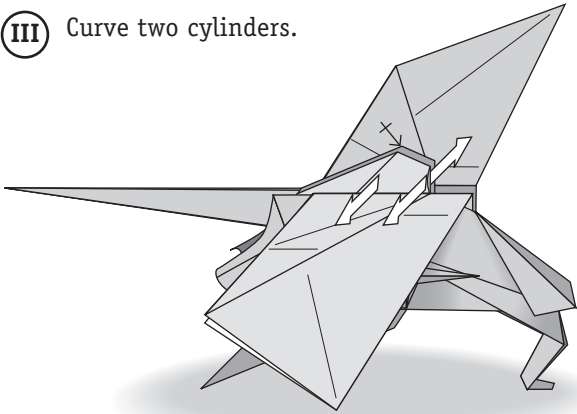

IV Ornithopter with two additional turbojet engines.

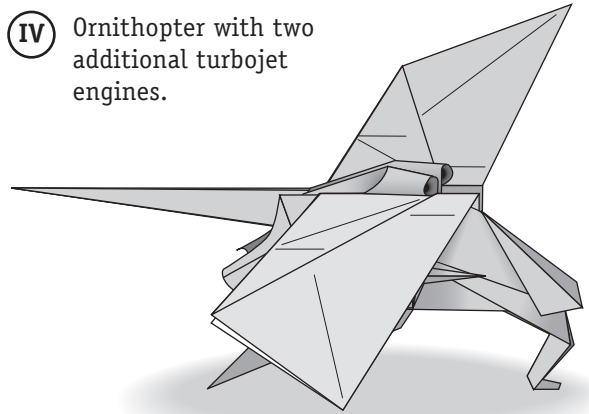

Fold an elevator.

A Spread the tail.

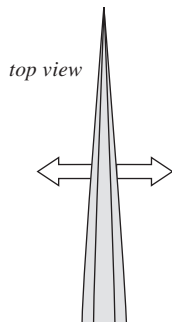

B Fold as shown.

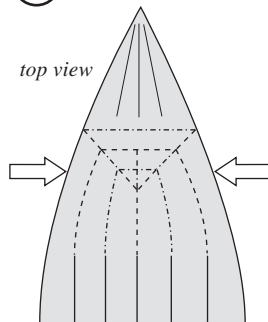

C Rotate to the right.

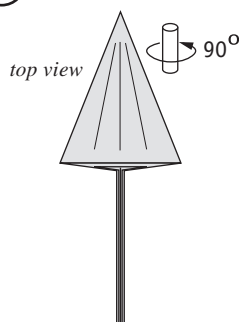

D Crimp fold.

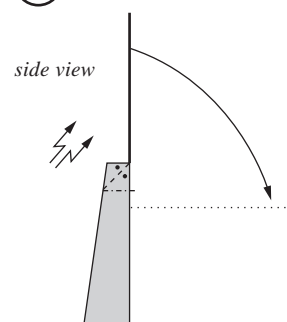

E Rotate downward.

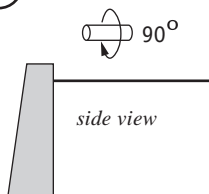

F Squash fold.

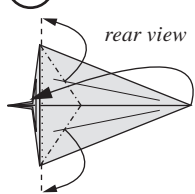

G Finished elevator.

